



# WE05-4RVLCH

## Transient Voltage Suppressor

### Features

- Low operating voltage: 5V
- Ultra low capacitance
- Solid-state silicon-avalanche and active circuit triggering technology
- Up to four I/O Lines of Protection
- Low Leakage

### IEC COMPATIBILITY (EN61000-4)

- IEC 61000-4-2 (ESD)  $\pm 25\text{kV}$  (air),  $\pm 20\text{kV}$  (contact)
- IEC 61000-4-4 (EFT) 40A (5/50ns)
- IEC 61000-4-5 (Lightning) 6A (8/20 $\mu\text{s}$ )

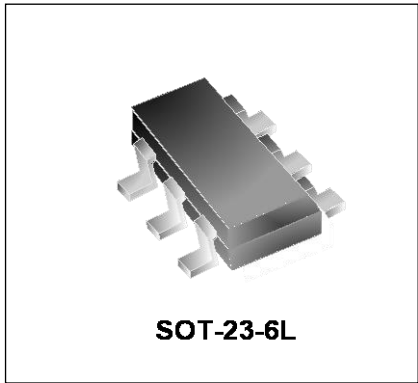

### Mechanical Characteristics

- SOT-23-6L package
- Marking : Making Code
- Packaging : Tape and Reel per EIA 481
- RoHS Compliant

### Applications

- Video/Graphics Card
- Digital Visual Interface (DVI)
- USB2.0 Power and Data lines protection
- Notebook and PC Computers
- Monitors and Flat Panel Displays

### Circuit Diagram

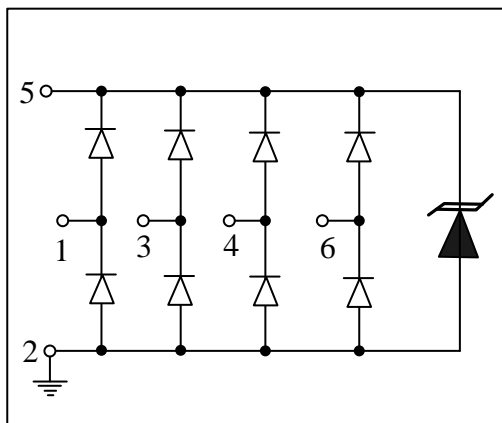

### Schematic & PIN Configuration

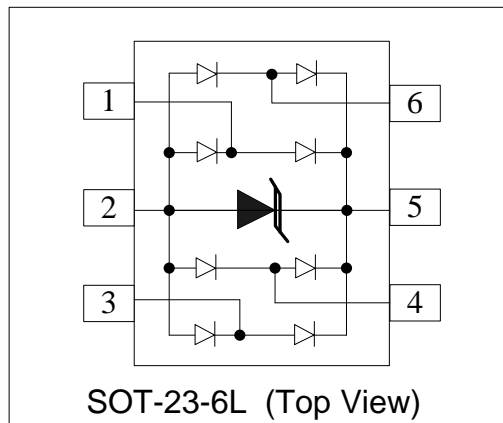

Absolute Maximum Rating			
Rating	Symbol	Value	Units
Peak Pulse Power ( $t_p=8/20\mu s$ )	$P_{PP}$	84	Watts
Peak Pulse Current ( $t_p=8/20\mu s$ )	$I_{PP}$	6	A
Operating Temperature	$T_J$	-55 to + 125	$^{\circ}C$
Storage Temperature	$T_{STG}$	-55 to +150	$^{\circ}C$

Electrical Parameters (T=25°C)

Symbol	Parameter
$I_{PP}$	Reverse Peak Pulse Current
$V_C$	Clamping Voltage @ $I_{PP}$
$V_{RWM}$	Reverse Stand-Off Voltage
$I_R$	Reverse Leakage Current @ $V_{RWM}$
$V_{BR}$	Breakdown Voltage @ $I_T$
$I_T$	Test Current
$I_F$	Forward Current
$V_F$	Forward Voltage @ $I_F$

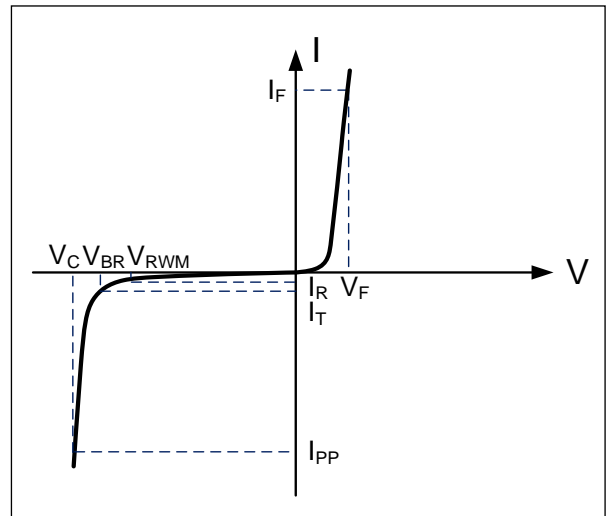

Electrical Characteristics

WE05-4RVLCH						
Parameter	Symbol	Conditions	Minimum	Typical	Maximum	Units
Reverse Stand-Off Voltage	$V_{RWM}$	Pin5 to pin2 T=25°C			5	V
Breakdown Voltage	$V_{BR}$	$I_T=1mA$ Pin 5 to pin2	6			V
Reverse Leakage Current	$I_R$	$V_{RWM}=5V, T=25^{\circ}C$ Pin 5 to pin2			500	nA
Forward Voltage	$V_F$	$I_T=10mA$	0.5		1.2	V
Clamping Voltage	$V_C$	$I_{PP}=6A, t_p=8/20\mu s$ Any I/O pin to ground		11	14	V
Dynamic Resistance <sup>1,2</sup>	$R_{DYN}$	TLP=0.2/100ns		0.96		$\Omega$
ESD Clamping Voltage <sup>1</sup>	$V_C$	$I_{PP} = 4A,$ $t_p = 0.2/100ns$ (TLP)		11		V
ESD Clamping Voltage <sup>1</sup>	$V_C$	$I_{PP} = 16A,$ $t_p = 0.2/100ns$ (TLP)		22.5		V
Junction Capacitance	$C_j$	$V_R = 0V, f = 1MHz$ I/O pin to GND		1.5	2	pF
		$V_R = 0V, f = 1MHz$ Between I/O pins		0.7	1	pF

Notes : 1. TLP Setting :  $t_p=100ns, t_r=0.2ns, I_{TLP}$  and  $V_{TLP}$  sample window: $t_1=70ns$  to  $t_2=90ns$ .  
 2. Dynamic resistance calculated from  $I_{PP}=4A$  to  $I_{PP}=16A$  using "Best Fit".

Typical Characteristics

Figure 1: Peak Pulse Power vs. Pulse Time

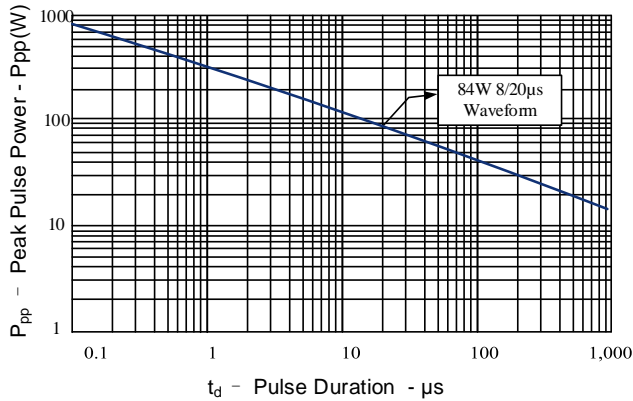

Figure 2: Power Derating Curve

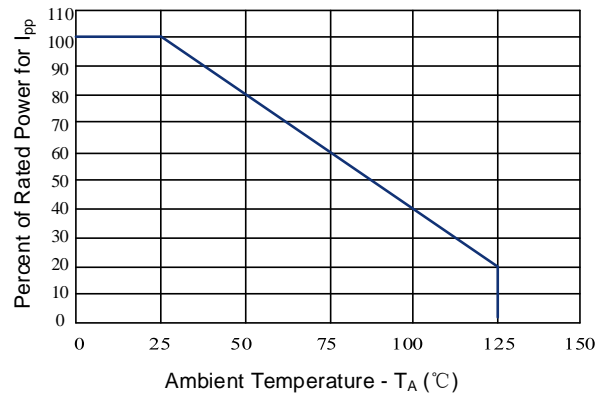

Figure 3: Clamping Voltage vs. Peak Pulse Current

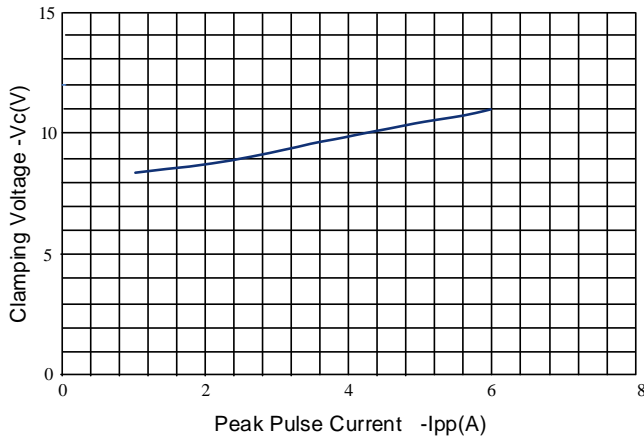

Figure 4: Normalized Junction Capacitance vs. Reverse Voltage (IO-GND)

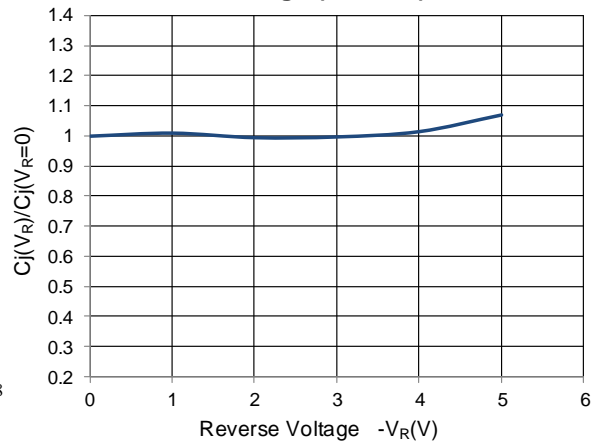

Figure 5: Pulse Waveform

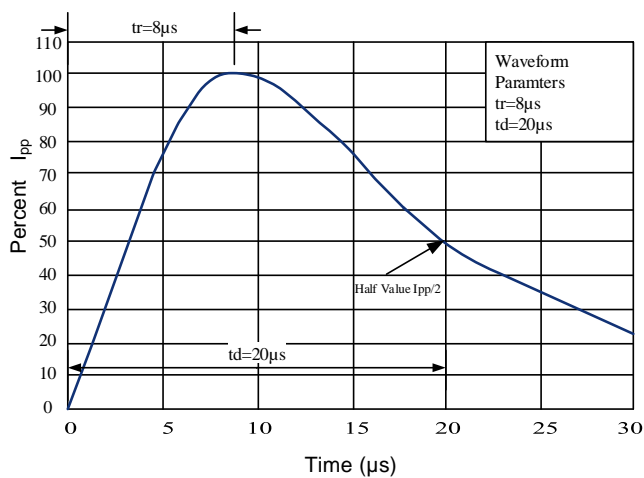
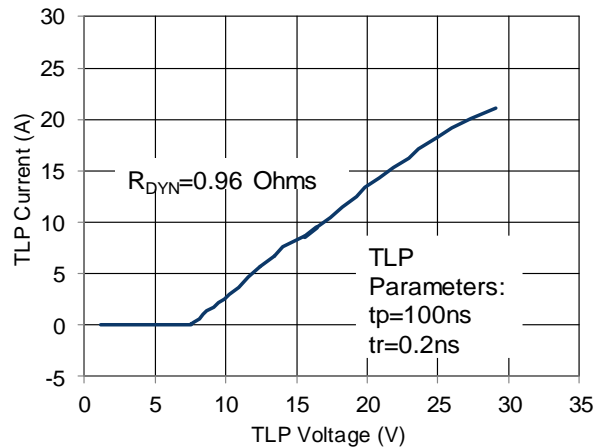
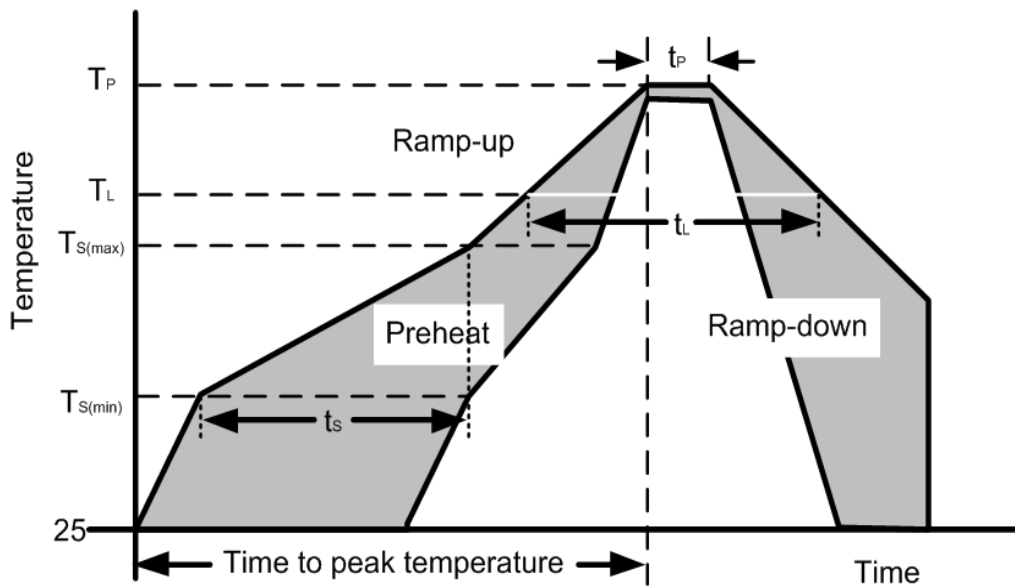

Figure 6: TLP I-V Curve



Soldering Parameters

Reflow Condition		Pb – Free assembly
Pre Heat	Temperature Min ( $T_{S(min)}$ )	150°C
	Temperature Max ( $T_{S(max)}$ )	200°C
	Time (min to max) ( $t_s$ )	60 – 190 secs
Average ramp up rate (Liquidus Temp) ( $T_L$ ) to peak		5°C/second max
$T_{S(max)}$ to $T_L$ —Ramp-up Rate		5°C/second max
Reflow	Temperature ( $T_L$ ) (Liquidus)	217°C
	Temperature ( $t_L$ )	60 – 150 seconds
Peak Temperature ( $T_P$ )		260+0/-5 °C
Time within actual peak Temperature ( $t_p$ )		20 – 40 seconds
Ramp-down Rate		5°C/second max
Time 25°C to peak Temperature ( $T_P$ )		8 minutes Max.
Do not exceed		280°C



Outline Drawing – SOT-23-6L

**PACKAGE OUTLINE**

SIDE VIEW SEE DETAIL A

DETAIL A

SOT-23-6L

DIMENSIONS				
DIM	INCHES		MILLIMETERS	
	MIN	MAX	MIN	MAX
A	0.035	0.057	0.90	1.45
A1	0.000	0.006	0.00	0.15
A2	0.035	0.051	0.90	1.30
b	0.014	0.020	0.35	0.50
c	0.003	0.008	0.08	0.20
D	0.110	0.119	2.80	3.02
E1	0.060	0.069	1.50	1.75
E	0.102	0.118	2.60	3.00
e	0.037 BSC		0.95 BSC	
e1	0.075 BSC		1.90 BSC	
L	0.014	0.024	0.35	0.60
L1	0.022	0.030	0.55	0.75
θ 1	0°	8°	0°	8°
N	6		6	

DIMENSIONS		
DIM	INCHES	MILLIMETERS
C	0.098	2.50
G	0.055	1.40
P	0.037	0.95
X	0.024	0.60
Y	0.043	1.10
Z	0.141	3.60

**Notes:**

Controlling Dimension: Millimeter.

Marking Codes

Part Number	WE05-4RVLCH
Marking Code	

Package Information

Qty: 3k/Reel

CONTACT INFORMATION

No.1001, Shiwan (7) Road, Pudong District, Shanghai, P.R.China.201207

Tel: 86-21-68969993 Fax: 86-21-50757680 Email: [market@way-on.com](mailto:market@way-on.com)

WAYON website: <http://www.way-on.com>

For additional information, please contact your local Sales Representative.

**WAYON**® is registered trademark of Wayon Corporation.

Specifications are subject to change without notice.  
The device characteristics and parameters in this data sheet can and do vary in different applications and actual device performance may vary over time.  
Users should verify actual device performance in their specific applications.